

SVC RECTIFIED TRANSMISSION SYSTEM USING PSO

¹Gagan Kumar Ahirwar, ²Prof. Indrajeet Kumar, ³Prof. Balram Yadav
¹M.tech Scholar, ²Assistant Professor, ³Head of Department
 Scope College of Engineering Bhopal

Abstract— This paper presents a Static VAR compensator (SVC) Model, the boundaries (K_p, K_i and K_d) of which are being chosen from advancements made by PSO. The best result from PSO is chosen and afterward fed into the SVC boundaries to get the improved result of something similar. A calculation has been produced for the equivalent dependent on PSO. The best and enhanced result from the calculation is seen. A 800KM transmission line and SVC is displayed in the MATLAB. The results can be checked with upgraded PSO and without PSO streamlining.

Keywords—Static VAR Compansator (SVC), PID Controller, AVR, TCR, Voltage regulation, MATLAB Simulink.

I. INTRODUCTION

Power system stability improvements is very important for large scale system. The AC power transmission system has diverse limits, classified as static limits and dynamic limits[2 3].Traditionally, fixed or mechanically switched shunt and series capacitors, reactors and synchronous generators were being used to enhance same types of stability augmentation[2]. For many reasons desired performance was being unable to achieve effectively. A static VAR compensator (SVC) is an electrical device for providing fast-acting reactive power compensation on high voltage transmission networks and it can contribute to improve the voltage profiles in the transient state . An SVC can be controlled externally by using properly designed different types of controllers which can improve voltage stability of a large scale power system. Authors also designed PI controller[6] and system performances were investigated. With a view to getting better performance PID controller has been designed for SVC to injects V_{qref} externally. The dynamic nature of the SVC lies in the use of thyristor devices (e.g. GTO, IGCT)[4]. Therefore, thyristor based SVC with PID controllers have been used to improve the performance of multi-machine power system.

II. CONTROL CONCEPT OF SVC

An SVC is a controlled shunt susceptance (B) which injects reactive power into thereby increasing the bus voltage back to its net desired voltage level. If bus voltage increases, the SVC will inject less (or TCR will absorb more) reactive power, and the result will be to achieve the desired bus voltage [Fig.1]. Here, $+Q_{cap}$ is a fixed capacitance value; therefore the magnitude of reactive power injected into the system, Q_{net} , is controlled by the magnitude of $-Q_{ind}$ reactive power absorbed by the TCR. The basis of the thyristor-controlled reactor(TCR) which conduct on alternate half-cycles of the supply frequency. If the thyristors are gated

into conduction precisely at the peaks of the supply voltage, full conduction results in the reactor, and the current is the same as though the thyristor controller were short circuited. SVC based control system is shown in Fig.1[2].

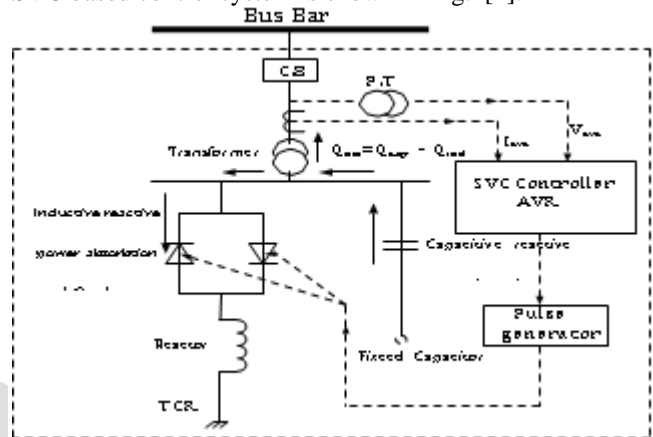

Fig.1 SVC based control system

III. PID CONTROLLER TUNING PROCESS

The process of selecting the controller parameters to meet given performance specifications is called PID tuning. Most PID controllers are adjusted on-site, many different types of tuning rules have been proposed in the literature. Using those tuning rules, delicate & fine tuning of PID controllers can be made on-site .

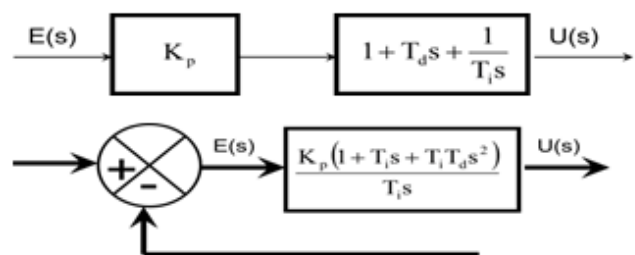

Fig.2 Block diagram of PID controller parameters

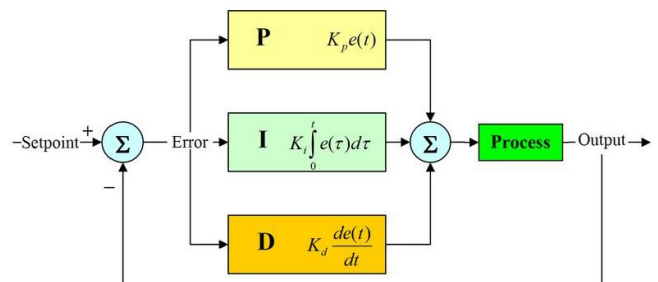

Fig. 3 PID BLOCK

Performance of PID depends on the gain parameters. so we need to adjust them .Different methods are used:

- 1) Open loop Method
- 2) Closed loop Method

OPEN LOOP METHOD

Here we apply a step to the process and get the response like as shown in the graph and get the dead time ,reaction rate and process gain..

- Put the controller in manual mode
- Wait until the process value (Y) is stable and not changing
- Step the output of the PID controller - The step must be big enough to see a significant change in the process value. A rule of thumb is the signal to noise ratio should be greater than 5.
- Collect data and plot as shown below.
- Repeat making the step in the opposite direction.
- K = the process gain=change in process value /change in manipulated value.

Close loop method

Another tuning method is formally known as the Ziegler Nichols method, by John G. Ziegler and Nathaniel B. Nichols in the 1944. As in the method above, the Ki and Kd gains are first set to zero. The P gain is increased until it reaches the ultimate gain, Ku, at which the output of the loop starts to oscillate. The main advantage of the closed-loop tuning method is that it considers the dynamics of all system components and therefore gives accurate results at the load where the test is performed. Another advantage is that the readings of Ku and Pu are easy to read and the period of oscillation can be accurately read even if the measurement is noisy. The disadvantages of the closed-loop tuning method are that when tuning unknown processes, the amplitudes of undampened oscillations can become excessive (unsafe) and the test can take a long time to perform. One can see that when tuning a slow process (period of oscillation of over an hour),it can take a long time before a state of sustained, undampened oscillation is achieved through this trial-and-error technique. For these reasons, other tuning techniques have also been developed and some of them are described below. First, it is essentially trial-and-error methods, since several values of gain must be tested before the ultimate gain. Second, while one loop is being tested in this manner, its output may affect several other loops, thus possibly upsetting an entire unit.

IV. PROBLEM STATEMENT

The project is objected to design a PID controller for a low damping plant. The low damping plants are the higher order plants which exhibits sluggish behaviour. This means that the plant has large settling time, large peak overshoot which are undesirable for better performance. Here we have selected a model transfer function of a low damping raw plant as follows:-

$$T(s) = (25.2*s^2 + 21.2*s + 3)/(s^5 + 16.58*s^4 + 25.41*s^3 + 17.18*s^2 + 11.70*s + 1)$$

For the plant model the transfer function is as follows:-

$$T1=[(25.2 \ 21.2 \ 3],[1 \ 16.58 \ 25.41 \ 17.18 \ 11.70 \ 1])$$

The parameters can be obtained as follows:-

$$S=Stepinfo\{T1,'RiseTimelimits',[0.1, 0.9]\}$$

The above command returns:-

- S = RiseTime : 2.1972 sec
- Settling Time : 33.513 sec
- Overshoot : 7.1023
- Peak : 3.2131
- Peak Time : 4.1789 sec

The plant model can be figured as :-

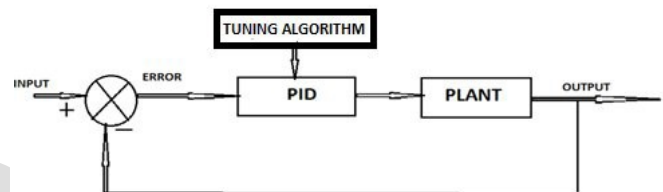

The open loop transfer function of the model :-

$$T(s) = (25.2*s^2 + 21.2*s + 3)/(s^5 + 16.58*s^4 + 25.41*s^3 + 17.18*s^2 + 11.70*s + 1)$$

Contribution of PID:-

$$PID(S) = (kD*s^2 + kI + kp*s)/S$$

So, the overall transfer function of the controlled model:-

$$C(S)/R(S) = PID(S)*T(S)/(1+PID(S)*T(S)) =$$

$$(25.2*kD*s^4) + (21.2*kD + 21.5*kP)*s^3 + (25.2*kI + 21.2*kP + 3*kD)*s^2 + (21.2*kI + 3*kP)*s + 3*KI$$

$$S^6 + 16.5*s^5 + (25.41 + 25.2*kD)*s^4 + (17.18 + 21.2*kD + 25.2*kP)*s^3 + (11.70 + 25.2*kI + 21.2*kP + 3*kD)*s^2 + (21.2*kI + 3*kP + 1)*s + 3*kI$$

V. CONCEPT OF FITNESS FUNCTION FOR THE DESIGN

For our case of design, we had to tune all the three parameters of PID such that it gives the best output results or in other words we have to optimize all the parameters of the PID for best results .Here we define a three dimensional search space in which all the three dimensions represent three different parameters of the PID. Each particular point in the search space represent a particular combination of [KP KI KD] for which a particular response is obtained The performance of the point or the combination of PID parameters is determined by a fitness function or the cost function. This fitness function consists of several component functions which are the performance index of the design. The point in the search space is the best point for which the fitness function attains an optimal value. For the case of our design, we have taken four component functions to define

fitness function. The fitness function is a function of steady state error, peak overshoot, rise time and settling time. However the contribution of these component functions towards the original fitness function is determined by a scale factor that depends upon the choice of the designer. For this design the best point is the point where the fitness function has the minimal value.

The chosen fitness function is:-

$$F = (1 - \exp(-\beta)) (MP + ESS) + (\exp(-\beta))(TS - Tr)$$

Where F:- Fitness function

Mp :- Peak Overshoot

Ts :- Settling Time

β :-Scaling Factor(Depends upon the choice of designer)

For our case of design we have taken the scaling factor $\beta = 1$.

In the matlab library we have defined a fitness function which has PID parameters as input values and it returns the fitness value of the PID based controlled model as its output. It has the format:-

Function [F] = fitness(K_D K_P K_I)

```
function F= tightnes(kd, kp, ki)
T1=tf([25.2*kd 21.2*kd+25.2*kp
25.2*ki+21.2*kp+3*kd 21.2*ki+3*kp 3*ki],[1 16.58 25.41+25.2*kd
17.18+21.2*kd+25.2*kp 11.70+25.2*ki+21.2*kp+3*kd
21.2*ki+3*kp+1 3*ki]);
S=stepinfo(T1,'RiseTimeLimits',[0.1 0.9]);
tr=S.RiseTime;
ts=S.SettlingTime;
Mp=S.Overshoot;
Ess=1/(1+dcgain(T1));
F=(1-exp(-0.5))*(Mp+Ess)+exp(-0.5)*(ts-tr);
```

We have used this fitness function for the performance evaluation of different combination of PID parameters reflected by the points in the three dimensional search space

VI. PARTICLE SWARM OPTIMIZATION

James Kennedy an American Social Psychologist along with Russell C. Eberhart innovated a new evolutionary computational technique termed as Particle Swarm

Optimization in 1995. The approach is suitable for solving nonlinear problem. The approach is based on the swarm behavior such as birds finding food by flocking. A basic variant of the PSO algorithm works by having a population (called a swarm) of candidate solution (called particles). These particles are moved around in the search-space according to a few simple formulae. The movements of the particles are guided by their own best known position in the search-space as well as the entire swarm's best known position. When improved positions are being discovered these will then come to guide the movements of the swarm. The process is repeated and by doing so it is hoped, but not guaranteed, that a satisfactory solution will eventually be discovered. Here in this technique a set of particles are put in d-dimensional search space with randomly choosing velocity and position. The initial position of the particle is taken as the best position for the start and then the velocity of the particle is updated based on the experience of other particles of the swarming population.

Algorithm for PSO

Particle swarm optimization is a population based stochastic optimization method. This algorithm was inspired from the social behavioral pattern of organisms, such as Bird flocks, fish schools, and sheep herds where aggregated behaviors are met, producing powerful, collision-free, synchronized moves. In such systems, the behavior of each swarm member is based on simple inherent responses, although their collective outcome is rather complex from a macroscopic point of view. For example, the flight of a bird flock can be simulated with relative accuracy by simply maintaining a target distance between each bird and its immediate neighbors. This distance may depend on its size and desirable behavior. The swarms can also react to the predator by rapidly changing their form, breaking into smaller swarms and re-uniting, illustrating a remarkable ability to respond collectively to external stimuli in order to preserve personal integrity.

The PSO algorithm consists of a number of particles that collectively move through the search space of the problem in order to find the global optima. Each particle is characterized by its position and fitness. Subsequently, the PSO algorithm updates the velocity vector for each particle then adds that velocity to the particle position. The velocity updates are influenced by both the best global solution associated with the highest fitness ever found in the whole swarm, and the best local solution associated with the highest fitness in the present population.

VII. PROPOSED PSO-PID

The implementation of SVC controller in the SMIB system will enhance the system stability through selecting the optimal PID controller parameters of SVC using PSO-PID tuning method. Fig.4 shows the block diagram of proposed PSO/MPSO-PID controller for the SMIB system with SVC. In the proposed PSO/MPSO-PID controlling method each particle contains three members K_p , K_i , & K_d . In other words the problem search space has three dimensions and each particle in the population must fly in a three dimensional space. Fig. 5 illustrates the flowchart of

implementing auto-tuning method for PID controller using PSO/MPSO algorithm to tune the PID Controller and collect the optimal parameters values. The initial values for velocity vector and position vector in the first iteration can be taken as follows

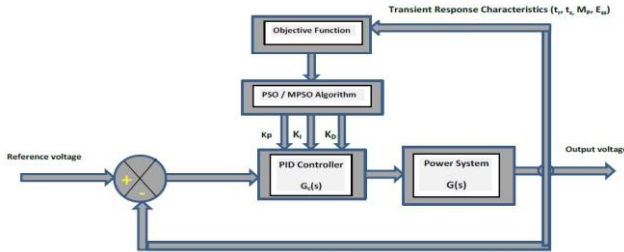

Fig 4. Block diagram of proposed PSO/MPSO-PID controller

$$\left. \begin{aligned} x_{i,1}^0 &= K_p^{min} + (K_p^{max} - K_p^{min}) * rand_{i,1}(0, 1) \\ x_{i,2}^0 &= K_i^{min} + (K_i^{max} - K_i^{min}) * rand_{i,2}(0, 1) \\ x_{i,3}^0 &= K_d^{min} + (K_d^{max} - K_d^{min}) * rand_{i,3}(0, 1) \end{aligned} \right\}$$

$$\left. \begin{aligned} v_{i,1}^0 &= \frac{x_{i,1}^0}{2} \\ v_{i,2}^0 &= \frac{x_{i,2}^0}{2} \\ v_{i,3}^0 &= \frac{x_{i,3}^0}{2} \end{aligned} \right\}$$

PSO PROGRAM

-Initially we fixed the values of PSO algorithm constants as :
 Inertia weight factor W = 0.3
 Acceleration constants C1 , C2 = 1.5
 As we have to optimize three parameters, namely KP ,KD ,KI of the controller, we have to search for their optimal value in the three dimensional search space, so we randomly initialized a swarm of population “100” in the three dimensional search space with [Xi,1 Xi,2 Xi,3] and [Vi1 Vi2 Vi3] as initial position and velocity.

-Calculated the initial fitness function of each point and the point with minimum fitness function is displayed as gbest (initial value of global best optima) and the optimal fitness function as fbest1(Initial best fitness function).

-Runned the program with the PSO algorithm with thousands (or even more numbers) of iterations and the program returned final optimal value of fitness function as “fbest” and final global optimum point as “Gbest”.

The Program for the Simulation Plot

```
clc
close all
kd=input('enter the value of kd');
kp=input('enter the value of kp');
ki=input('enter the value of ki');
T1=tf([25.2*kd 21.2*kd+25.2*kp 25.2*ki+21.2*kp+3*kd 21.2*ki+3*Kp
3*ki],[1 16.58 25.41+25.2*kd 17.18+21.2*kd+25.2*kp
11.70+25.2*ki+21.2*kp+3*kd 21.2*ki+3*kp+1 3*ki]);
ltiview
```

PROGRAM FOR PSO

```
clc
close all
c1=1.5;
c2=1.5;
for i=1:50
for j=1:3
X(i,j)=i*rand;
V(i,j)=i*rand;
Pbest(i,j)=X(i,j);
end
end
for i=50:100
for j=1:3
X(i,j)=0.5*i*rand;
V(i,j)=0.5*i*rand;
Pbest(i,j)=X(i,j);
end
end
for i=1:100
kd=X(i,1);
kp=X(i,2);
ki=X(i,3);
F(i,1)=fitness(kd kp ki);
end
k=1;
m=1;
fbest=F(1,1);
while m<100
if fbest>F(m,1)
fbest=F(m,1);
k=m;
end
m=m+1;
end
k1=k;
fbest1=fbest;
Gbest=[X(k,1) X(k,2) X(k,3)]
gbest=Gbest;
k1
fbest1
```

```

gbest
for M=1:50

for i=1:100
for j=1:3
V(i,j)=0.5*(100-i)*V(i,j)+c1*rand*(Pbest(i,j)-X(i,j))+c2*rand*(Gbest(1,j)-X(i,j));
X(i,j)=X(i,j)+V(i,j);
and
kd1=X(i,1);
kp1=X(i,2);
ki1=X(i,3);
kd=Pbest(i,1);

kp=Pbest(i,2);
ki=Pbest(i,3);
L=tightnes(kd,kp,ki);
P=tightnes(kd1,kp1,ki1);
if P<L
Pbest(i,1)=X(i,1);
Pbest(i,2)=X(i,2);
Pbest(i,3)=X(i,3);
and
and
for i=1:100

kd=Pbest(i,1);
kp=Pbest(i,2);
ki=Pbest(i,3);
F(i,1)=tightnes(kd,kp,ki);

and
m=1;
k=1;
while m<100
if fbest>F(m,1)
fbest=F(m,1);
k=m;
and
m=m+1;

and
Gbest=[Pbest(k,1) Pbest(k,2) Pbest(k,3)];
and
    
```

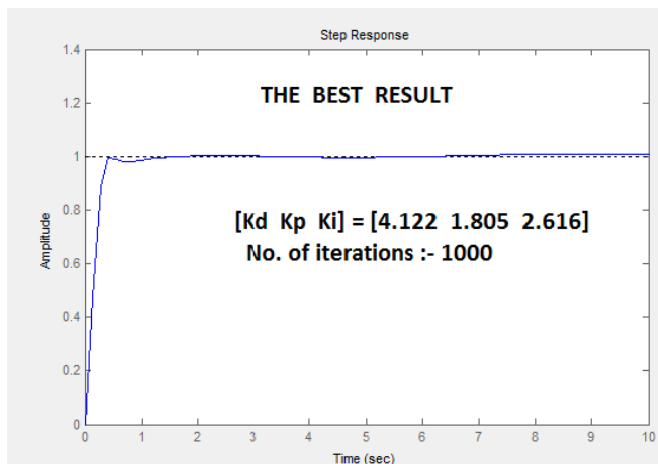

• So the optimal Value Of [Kd Kp Ki] will be 4.122, 1.805 & 2.616 which we are going to utilize in SVC to get the optimal output

VIII. SVC MODEL SIMULATION & RESULT ANALYSIS

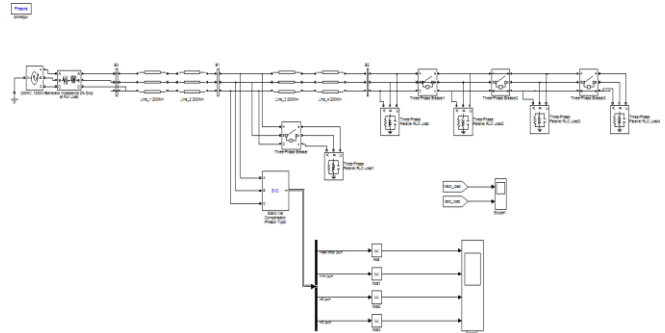

Fig 5. Proposed SVC Model

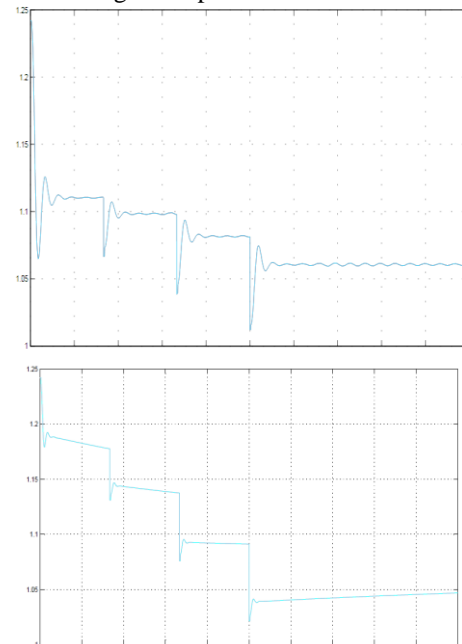

Fig 7 . Voltage waveform after Tuning

- It can be clearly seen in fig 6 and fig 7 that the proposed scheme gives smooth voltage waveform in the long transmission line with reduced sub transient peak voltage. it seen that on the use of value obtained by PSO algorithm for PID constants a sub transient free response is seen.
- It improves the total harmonic distortion of the SVC model and hence the optimized value has increased the overall power factor if the system
- The latch jumps are rectified in the current waveform also termed as Gibson jumps and it shows a high level of filtration in the current waveforms as can be seen in fig 8 and 9.this reduces the current harmonics .

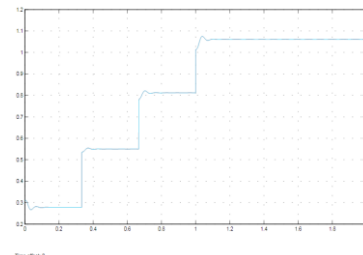

Fig 8. Current waveform without tuning

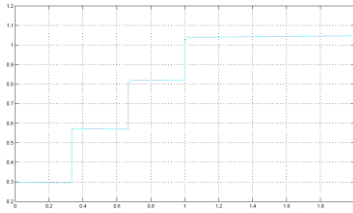

Fig 9. Current waveform after tuning

IX. CONCLUSION

This paper presents the modified PSO algorithm for tuning of SVC which in turn improves the reactive power compensation capability of SVC and thus gives better results. The research paper problem is framed as an optimization problem in terms of PID controller parameters, and the MPSO algorithm is used to find out the optimal parameters values. The effectiveness of the proposed technique is examined under different loading conditions, and the results are compared with the classical version of PSO and ZN tuning methods. Thus we get the optimal output from our study.

REFERENCES

- [1] H. Saadat, "Power System Analysis," McGraw Hill International Editions, 1999.
- [2] H. Rahman, Dr. F. Rahman, and H. O.-Rashid, "Stability Improvement of Power System By Using SVC With PID Controller," *International Journal of Emerging Technology and Advanced Engineering (IJETAE)*, vol. 2, no. 7, pp. 226-233, July 2012.
- [3] H. Rahman, Dr. F. Rahman, and H. O.-Rashid, "Power System Stability Improvement By Using SVC With TID Tuned PID Controller," *International Journal of Advanced Research in Computer Engineering & Technology (IJARCET)*, vol. 1, no. 8, pp. 93-98, Oct. 2012.
- [4] H. Rahman, Dr. F. Rahman, and H. O.-Rashid, "Improvement of Power System Stability Using Static Var Compensator with Controller," *International Journal of Advanced Research in Computer Engineering & Technology (IJARCET)*, vol. 1, no. 9, pp. 200-205, Nov. 2012.
- [5] A. K. Mohanty, and A. K. Barik, "Power System Stability Improvement Using FACTS Devices," *International Journal of Modern Engineering Research (IJMER)*, vol.1, no. 2, pp-666-672, Nov.-Dec. 2011.
- [6] J. G. Ziegler and N. B. Nichols, "Optimum Settings for Automatic Controllers," *Transactions of ASME*, vol. 64, pp. 759-765, 1942.
- [7] J. Kennedy and R. Eberhart, "Particle Swarm Optimization," *Proceedings of IEEE International Conference on Neural Networks*, Perth, Australia, vol. IV, pp. 1942-1948, 27 Nov.-1 Dec., 1995.
- [8] A. E. Hammad, "Analysis of Power System Stability Enhancement by Static VAR Compensators," *IEEE Transactions on Power Systems*, vol. 1, no. 4, pp. 222- 227, Nov. 1986.
- [9] P. Srihari, and G. S. Reddy, "Effective Way to Damping Power Oscillations using Static VAR Compensator with Fuzzy Logic Controller," *International Journal on Technical and Physical Problems of Engineering (IJTPE)*, vol. 4, no. 13, pp. 89-94, Dec. 2012.
- [10] Y. Ma, S. Chen, and B. Zhang, "A Study on Nonlinear SVC Control for Improving Power System Stability," *Proceedings of IEEE Region 10 Conference on Computer, Communication, Control and Power Engineering (TENCON'93)*, Beijing, China, vol. 5, pp. 166-169, 19-21 Oct. 1993.
- [11] R. V. Dukkupati, "Control Systems," Narosa Publishing House, 2005.
- [12] K. Ang, G. Chong, and Y. Li, "PID Control System Analysis, Design, and Technology," *IEEE Trans. Control System Technology*, vol. 13, pp. 559-576, July 2005.
- [13] K. S. Ismail, F. M. Tuaimah, and R. A. Hummadi, "DC Motor Speed Controller Design using Pole Assignment Technique for Industrial Application," *Journal of Engineering*, vol. 17, no. 3, pp. 466-472, June 2011.
- [14] B. S. Manke, "Linear Control Systems with MATLAB Applications," Khanna Publishers, 8th Edition, 2006.
- [15] K. J. Åström and R. M. Murray, "Feedback Systems: An Introduction for Scientists and Engineers," Princeton University Press, Princeton, NJ, 2008.
- [16] K. J. Åström and T. Hägglund, "PID Controllers: Theory, Design, and Tuning," Instrument Society of America, Research Triangle Park, NC, 2nd Edition, 1995.
- [17] K. E. Parsopoulos, M. N. Vrahatis, "Particle Swarm Optimization and Intelligence: Advances and Applications," Information Science Reference, NY, USA, 2010.
- [18] M. Clerc, "The swarm and the Queen: Towards a Deterministic and Adaptive Particle Swarm Optimization," *Proceedings of International Conference on Evolutionary Computation*, France Telecom, Annecy, France, vol. 3, pp. 1951-1957, 06-09 July, 1999.
- [19] Z.-L. Gaing, "A Particle Swarm Optimization Approach for Optimum Design of PID Controller in AVR System," *IEEE Transactions on Energy Conversion*, vol. 19, no. 2, pp. 384-391, June 2004.
- [20] T. O. Mahony, C. J. Downing, and K. Fatla, "Genetic Algorithm for PID Parameter Optimization: Minimizing Error Criteria," *Proceedings of International Conference on Process Control and Instrumentation*, Glasgow, UK, pp. 148-153, 26-28 July, 2000.