

## DESIGN AND SIMULATION OF LUO CONVERTER FOR DC MOTOR CONTROL FOR AN ELECTRIC VEHICLE APPLICATIONS

Prof. N. D. Mehta<sup>1</sup>, Dr. A. M. Haque<sup>2</sup>

Power Electronics Department, VGEC, Chandkheda, India

**Abstract:** DC voltage provided by battery contains high voltage ripples and it is not constant enough, thus it is not applicable for most devices like electric-vehicle controller. DC-DC converters are employed to attenuate the ripples regardless of change in the load voltage. In the existing method, the classical buck converter for electric vehicle applications does not meet the load requirement containing more ripples on the output voltage and parasitic effects. To overcome this problem the advanced developed DC-DC Luo-converter technology is introduced. Luo converter is the developed converter derived from the buck-boost converter. This paper proposes the stable and ripple free output voltage from the design of developed DC-DC converter topology. In this proposed model the additional filter element in the Luo-converter eliminate the output ripples and effectively enhance the output voltage level. A computer simulation using MATLAB/SIMULINK confirms the results.

**Keywords:** DC-DC converter, Electric Vehicle, Low Pass Filter, LUO converter.

### I. INTRODUCTION

THIS Conversion technique is one of the major research area in the field of power electronics. The equipment's used for conversion technique are found to have applications in industry, research and development, various organizations and in daily life. All the existing DC/DC converters are designed to meet the requirements of certain applications only[1]. The conventional types[2] of DC/DC converters include Buck converter, Boost converter, Buck-Boost converter, Cuk converter etc. Among these, boost converter is found to be applicable in large number of applications like, Hybrid Electric Vehicles (HEV), lighting systems, tramways, railway electrification.[3] The DC-DC conversion technology is a domain of power electronics and drives, and is continuously developing since last six decades. DC-DC converters are widely used in industrial applications and computer hardware circuits. Its market is undergoing evaluate changes as a result of two major trends in the electronics industry like low voltage and high power density. From this investigation, it can be seen that the production of dc-dc converters in the world market is much higher than that of ac-dc converters. In 1920s the dc-dc conversion process is started. The simplest dc-dc converter is a formal voltage conversion or voltage divider circuit [4], but it only transfers output voltage lower than input voltage with poor efficiency. The multiple-quadrant chopper[5] is the second step in dc-dc conversion more time has been spent for to find equipment to convert the dc energy source of one form voltage to another

DC actuator with another voltage form, as does a transformer employed in AC-AC conversion. Some initial types of DC-DC[6] converters were used in industrial applications before the Second World War. Research of DC-DC converter was jammed during the war, but applications of DC-DC converters were recognized. After the war, communication technology developed very quickly and required low voltage DC power supplies for the communication. This resulted in the rapid development of DC-DC conversion techniques. Initial stage prototypes can be derived from choppers. The emerging DC-DC converters can be offered as a method to generate multiple output voltage levels from a single source dc supply voltage to feed the different sub-circuits in the device [7]. This method of generating multiple output voltage levels from a single battery source can reduce the area of the device substantially. On the other hand dc supply voltage provided by battery or rectifier contains high voltage ripples and it is not constant enough, thus it is not applicable for most devices. DC-DC regulators are employed to attenuate the ripples regardless of change in the load current or input voltage [8]. Buck converter is a type of switching-mode power supply which is used for stepping-down dc voltage level. Switch controller circuit and power circuit are two main parts of buck converter circuit. One of the most critical issues for the environment today is pollution generated by hydro-carbon gases, which is one of the main sources of power for transportation. Hybrid Electric Vehicles (HEV)[9] and Full Electric Vehicles (EV) are rapidly advancing as alternative power trains for green transportation. The electric vehicle application not only involves the traction parts, but it is also generating the new applications for conversion of electric power from load to source. One of the key blocks inside hybrid electric vehicles is the DC-DC converter for auxiliary power supply of electric loads. Handling of the electric energy transfer from the 12V DC bus to the high voltage DC bus become possible which is invariably used in electric traction applications. The DC-DC converter enables [10] the energy transfer between the high voltage side and low voltage side giving tremendous advantages in terms of low cost, flexible, reliable and efficient, increased due to the possible constraints of easy to make synchronous rectification and implementation. The features include resonant clamping circuit implementation in the boost mode and soft-switching operation, due to phase shift operation, in the buck mode, without need additional devices, and provide high efficiency and easy to control. Power electronic converters having efficient semiconductor devices are key components to meet the targets of extended mileage range

and reduced pollution. The rapidly efficient DC-DC converters has to be used to provide appropriate voltage levels and the power management between different energy level sources and storage elements. The proposed developed DC-DC converter is Luo converter it overcomes the parasitic problems present in the classical dc-dc converter [11].

II. WORKING OF LUO CONVERTER

Modes of operation

Fig 1 shows the circuit diagram for developed dc-dc Luo converter. The harmonics Levels present in the Luo converter is less compared to the classical buck converter. In the circuit, S is the power switch and D is the freewheeling diode. The energy storage passive elements are inductors maintaining the Integrity of the Specifications L1, L2 and capacitors C1, C2, R is the load resistance. To analyze the operation of the Luo converter, the circuit can be divided into two modes of operation.

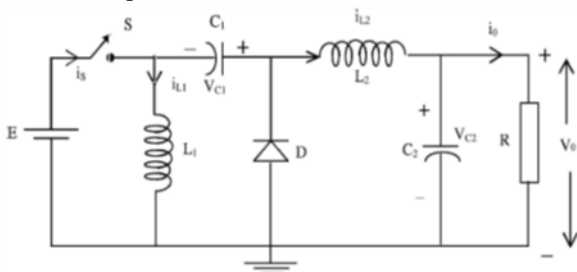

Fig. 1.Circuit diagram of Luo converter.

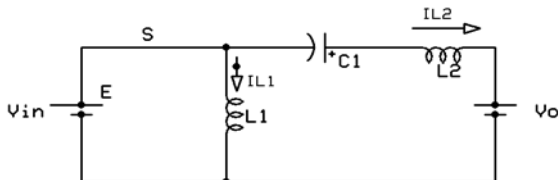

Fig. 2 Principle of Operation of Luo Converter

Mode 1: when the switch is ON, the inductor L1 is charged by the supply voltage E. At the same time, the inductor L2 absorbs the energy from source and the capacitor C1. The load is supplied by the capacitor C2. The equivalent circuit of Luo converter in mode 1 operation is shown in (1).

Mode 2: switch is in OFF state, and hence, the current is drawn from the source becomes zero, as shown in (2). Current  $i_{L1}$  flows through the freewheeling diode to charge the capacitor C1. Current  $i_{L2}$  flows through C2 – R circuit and the freewheeling diode D to keep itself continuous. If adding additional filter components like inductor and capacitor to reduce the harmonic levels of the output voltage. In Discontinuous Conduction Mode [12], output should be in the form of discontinuous. In this mode diode is not present and inductor discharge through V0 and L2. The output stage of the Luo buck converter is comprised of an inductor and capacitor. The output stages stores and delivers energy to the load, and smooths out the switch node voltage to produce a constant output voltage. Inductor selection directly influences

the amount of current ripple seen on the inductor current, as well as the current capability of the buck converter itself. Inductors [13] vary from manufacturer to manufacturer in both material and value, and typically have a tolerance of 20%. Inductors have an inherent DC Resistance (DCR) that impacts the performance of the output stage. Minimizing the DCR improves the overall performance of the converter. For that application it requires a high load current, it is recommended to select an inductor with a low DCR. The DCR is smaller for lower inductor values, but there is a trade-off between inductance and ripple current; the lower the inductance, the higher the ripple current through the inductor. A minimum inductance must be met in order to meet the ripple current requirements of the specific application circuit. The output capacitance directly affects the output voltage of the converter and the response time of the output feedback loop [14], also the amount of output voltage overshoot that occurs during changes in load current. A ripple voltage exists on the DC output as the current through the inductor and capacitor increases and decreases. Increasing the value of output capacitance value reduces the amount of voltage ripple present in the circuit. However there is a tradeoff between capacitance and the output response. Increasing the capacitance reduces the output voltage ripple and output voltage overshoot, but increases the response time it takes output voltage feedback loop to respond to changes in load. Therefore, a minimum capacitance must be considered, in order to reduce the ripple voltage and voltage overshoot requirements of the converter, while maintaining a feedback loop that can respond quickly enough to load changes. Capacitors also have a parasitic series resistance, known as the Equivalent Series Resistance (ESR). The steady state capacitor value is 0 A shown in fig (3).

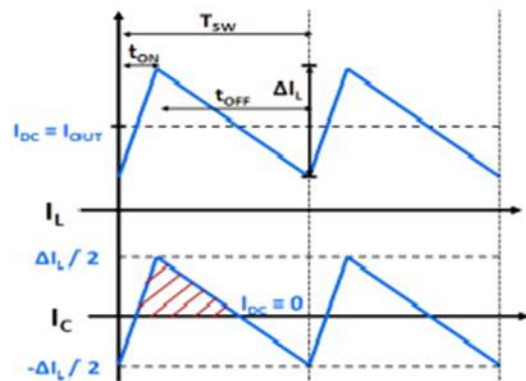

Fig. 3. Principle of Luo Converter and Inductor Current and Capacitor Voltage

The ESR impacts the output voltage ripple and the overall efficiency of the converter. Because of this, designers are moving to low ESR designs[15]. Surface mount ceramic capacitors are becoming prevalent in systems that require high performance in a small form factor. The choice of multiple capacitors connected in parallel allows designers to achieve the necessary capacitance for the system while greatly reducing the equivalent ESR.

III. ANALYSIS OF LUO CONVERTER

Duty Cycle,  $a = T_{on}/T$  ..... (1)

Output Voltage  $V_o = (V_{in}(a))/(1 - a)$ ..... (2)

Average Voltage across the capacitor  $C_1$  is,  
 $V_{C1} = (V_{in}(a))/(1 - a)$  ..... (3)

Peaktpeakinductorcurrent  $L_1$  is,  
 $\Delta I_{L1} = (V_{in}(aT))/(L1)$  ..... (4)

Peaktpeakinductorcurrent  $L_2$  is,  
 $\Delta I_{L2} = (V_{in}(aT))/(L2)$  ..... (5)

Inductor values  $L_1$  and  $L_2$  [15] can be found out from Eq. (4) and (5). The charge on series capacitor ( $C_1$ ) increases during off period by  $I_{L2} (=I_o)$  and decreases during on period by  $I_{L1}$  [16]. The change in charge on  $C_1$  must be zero Peak to peak ripple Voltage across the capacitor  $C_1$  and value of  $C_1$  is calculated by the equation

$C_1 = (I_{L1}(1 - a)T)/(\Delta v_{c1})$  ..... (6)

The inductor current  $I_{L2}$ ,  
 $I_{L2} = (I_{L1}(1 - a))/(a)$  ..... (7)

TABLE I  
 DESIGN PARAMETERS AND SIMULATION  
 CONDITIONS

Sr. No.	Parameter	Rating
1	Input voltage	60V
2	Output voltage	12V
3	Capacitor $C_1, C_2$	0.1mF
4	Inductor $L_1, L_2$	0.27mH
5	Switching frequency	50KHz
6	Load current	10A

IV. SIMULATION RESULT AND DISCUSSION

In electric vehicle applications, different kinds of electric loads [17] are used. The applicability of the concept on different electric loads used in electric vehicle applications is tested with simulation models that would provide the most realistic predictions [18]. SIMULINK model for Luo converter is shown in Fig. 1.

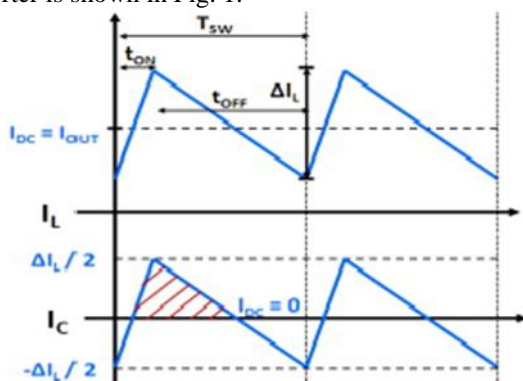

The duty cycle 'a' can be generated by comparing the reference dc signal  $V_r$  with a saw tooth carrier signal  $V_{cr}$ . This is shown in fig(e), Modulation index [19], [20], [21] is the ratio of carrier signal to reference signal the duty cycle a can be varied from 0 to 1. To obtain the square wave pulses [22] compare these signals by a comparator to generate the difference  $(V_c - V_{cr})$ . Any variation in  $V_{cr}$  varies linearly with the duty cycle 'a'.

TABLE II: RESULT OF OPEN LOOP SIMULATION OF  
 LUO CONVERTER

Duty Cycle (a)	Output Voltage (Vo)	Speed (RPM)
30 %	180	1290
35 %	189	1358
40 %	199	1434
45 %	210	1521
50 %	223	1624

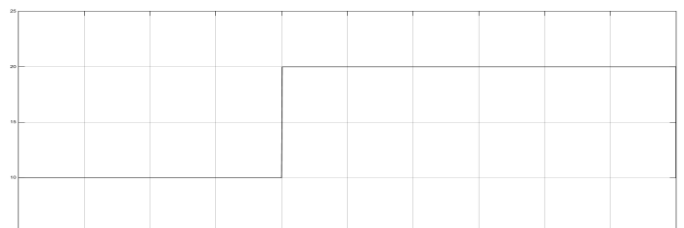
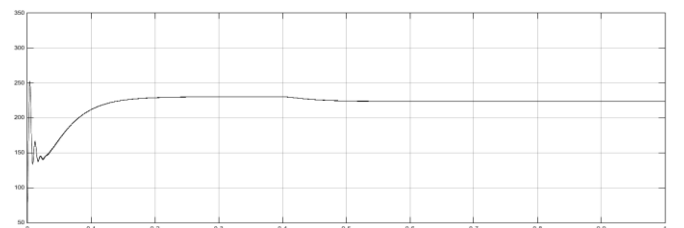
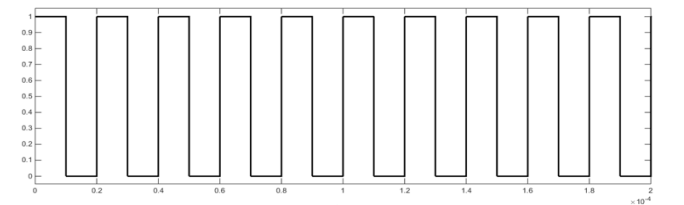
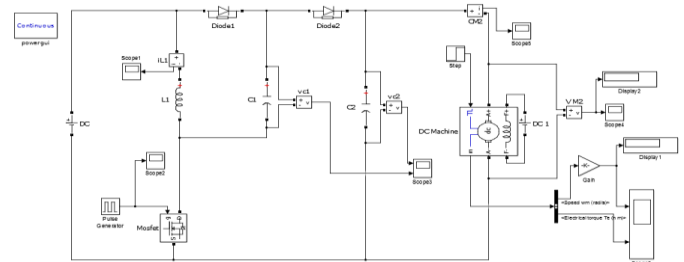

Fig. 4. Simulation of the Open Loop Luo Converter

Fig. 5 shows the simulation diagram, Load pattern and response of the speed of the dc motor using closed loop simulation using MATLAB Simulink.

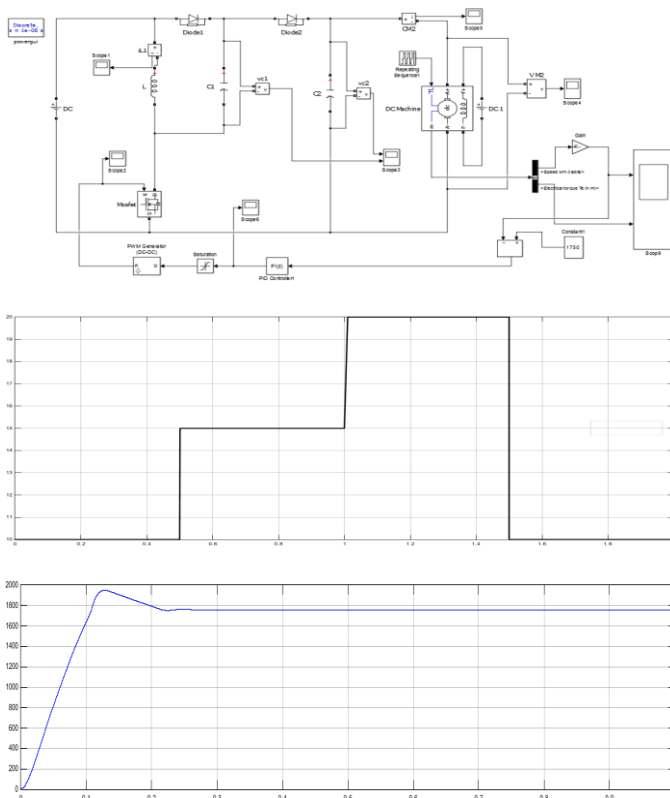

Fig. 5. Simulation of the Closed Loop Luo Converter

## V. CONCLUSION

In the current study, the proposed developed Luo converter has been shown to be capable of providing a topology that reduces the output ripple and parasitic effects. Using this method stable and ripple free output is obtained. Simulation results verified the design and calculations. This developed dc-dc converters are suitable and convenient to be applied into electric vehicle applications with low ripples. The advanced dc-dc converter enhancement technique such as Luo converter is used. The main objective is to reach the high efficiency, low THD, high power density and simple structures.

## REFERENCES

- [1] A.Manikandan, N.Vadivel, "Design And Implementation Of Luo Converter For Electric Vehicle Applications" International Journal of Engineering Trends and Technology (IJETT) – pp. 4437-4441 Volume 4 Issue 10 - Oct 2013
- [2] Marian K. Kazimierczuk, "Pulse-width Modulated DC-DC Power Converters", Edition, Wiley.
- [3] Ned Mohan, Tore M. Undeland, William P. Robbins, "Power Electronics: Converters, Applications, and Design", 3rd Edition, Wiley.
- [4] Jerrold Foutz, "Switching-Mode Power Supply Design Tutorial Introduction", SMPS Technology, <http://www.smpstech.com/tutorial/t01int.htm>, accessed: Mar 2012.
- [5] Abraham I. Pressman, "Switching Power Supply Design", Second Edition, McGraw-Hill, Publication Date: Nov 1997.
- [6] Chester Simpson, "Linear and Switching Voltage Regulator Fundamentals", National Semiconductor, <http://www.national.com/assets/en/appnotes/f4.pdf>, accessed: Mar 2012
- [7] Maxim Integrated Products, Inc., "DC-DC Converter Tutorial", Application Note 2031, Nov 29, 2001.
- [8] Ray Ridley, "CURRENT MODE or VOLTAGE MODE", Switching Power Magazine, Oct2000
- [9] MadhuravasalVijayaraghavan G., "Extreme temperature switch mode power supply based on vee-square control using silicon carbide, silicon on sapphire, hybrid technology", Doctoral Thesis, Oklahoma State University, 2009.
- [10] L. K. Wong, T. K. Man, "How to best implement a synchronous buck converter", National Semiconductor, Apr 2008
- [11] Fang Lin and Hong Ye [2004], "Positive Output Multiple-Lift Push-Pull Switched-Capacitor Luo-Converter",
- [12] He.Ye and Luo F.L.[2005], "Analysis of Luo converter with Voltage Lift Circuit", IEEE Precedes Electrical on Power Applications, Volume:52, No.5, Page1239-1252.
- [13] Luo.F.L and Ye.h [1999], "Positive output cascade Boost converters", IEEE Precedes Electrical on Power Applications, Volume: 151, No.5, Page:590-606.
- [14] Fang Lin Luo and Hong ye [2007], "mathematical modeling for Dc- Dc converter" IEEE transactions on power electronics, vol. 22, no. 1
- [15] G.Ch.Ioannidis, C.S.Psomopoulos "AC-DC & DC-DC Converters for DC Motor Drives" Proceedings of the 2013 International Conference on Electronics and Communication Systems
- [16] R. Rajalakshmi and G.Rajasekar "Design and Implementation of Non-Linear Controller Using Positive Output Elementary Split Inductor Type Boost Converter" International Journal of Advances in Engineering, 2015, 1(3), 235 – 244
- [17] CharuSnehaKatta, YellaiahPonnam "Simulation of Dc Motor Fed Dc-Dc Converter with High Step-Up Voltage Gain" International Journal of Engineering Research and Development.
- [18] K. Ramash Kumar, S. Jeevananthan "PI Control for Positive Output Elementary Super Lift Luo Converter" World Academy of Science, Engineering and Technology Volume: 2010-03-23
- [19] Ms.Josily Jose, Jayanand. B "Simulation and Implementation of SuperliftLuo converter" 2013 International Conference on Renewable Energy and Sustainable Energy [ICRESE'13]
- [20] Alfred Baghrmian, HasanGhorbaniEshyani "Fuzzy Controller of Luo Converter for Controlling of DC Motors Speed" 4th Power Electronics, Drive Systems & Technologies Conference (PEDSTC2013), Feb 13-14, 2013, Tehran, Iran



- [21] Fang Lin Luo “Positive Output Super-Lift Converters”  
IEEE Transaction on Power Electronics, volume.18 18,  
NO. 1, January 2003
- [22] P.M.Meshram and RohitG.Kanojaiya “Tuning of PID  
controller using Ziegler-Nichols Method for speed  
control of DC Motor” IEEE-International conference in  
Engineering, Science and Management (ICAESM-2012)
- [23] Victor Dutta, Terence O’Donnell, SubhramitraBorkakati  
“PI-Fuzzy rule based controller for Analysis and  
performance evaluation of dc motor speed control” in  
The 2nd IEEE Conference on Power Engineering and  
Renewable Energy , ICPERE 2014
- [24] Philip A.Adewuyi “DC Motor speed control: A case  
between PI and Fussy logic controller”International  
journal of multidisciplinary science and engineering,  
vol.4, no,4, may 2013
- [25] SujitKr.Gupta , PragyVrashney “Fractional Fussy PID  
controller for speed control of DC motor” 2013 Third  
international conference on advance in computing and  
communication.
- [26] B. Balaji and J. Barnabas Paul Glady “ Simulation and  
fault diagnosis of positive output elementary super lift  
Luo converter” ARPJ Journal of Engineering and  
Applied Sciences.
- [27] Muhammad Saleem , Itafhussain “Analysis and  
Comparison of DC-DC Boost Converters with High  
Voltage Conversion Ratio” World Applied Sciences  
Journal 23 (11): 1471-1480, 2013
- [28] CharuSnehakatta , YellaiahPonnamm “ Simulation of Dc  
Motor Fed Dc-Dc Converter with High Step-Up Voltage  
Gain” International Journal of Engineering Research and  
Development
- [29] V.K.Mehta and Rohit Mehta “Principal of Electrical  
Machines” S.Chand and company ltd.
- [30] Silpa.N, Chitra.J “An Improved Luo Converter for  
High Voltage Applications” International Journal of  
Emerging Technology and Advanced Engineering.  
Volume 4, Issue 5, May 2014.